

# TECH BRIEF 93

## RONDO BOOSTR BRACKET

**Introducing the NEW Rondo BoostR Bracket - Small in size, Big on Performance**

Engineered to transform steel stud wall construction, Rondo BoostR bracket is a smart solution enabling extended stud spans, increased wall heights, and greater material efficiency by reducing stud width, thickness, and the need for noggings.

### **BoostR Bracket by Rondo: The Small Bracket with BIG Potential!**

The BoostR Bracket from Rondo is designed to revolutionise steel stud wall construction. Its primary function: enabling steel studs to bypass the primary structure—whether steel or concrete—and be securely anchored, delivering a range of significant benefits:

**Extended Stud Spans:** Achieve greater distances without sacrificing stability.

**Increased Stud Heights:** Build taller, more robust walls with confidence.

**Enhanced Material Efficiency:** Reduce stud width, thickness (BMT), and the need for noggings.

**Structural Adaptability:** Built-in slots accommodate movement for deflection.

While the BoostR Bracket already enhances flexibility in stud wall design and construction, its full capability extends beyond traditional uses to areas such as soffits, feature framing for facades, and much more. With a bespoke technical design, the versatility, and possibilities of the Rondo BoostR Bracket are endless.

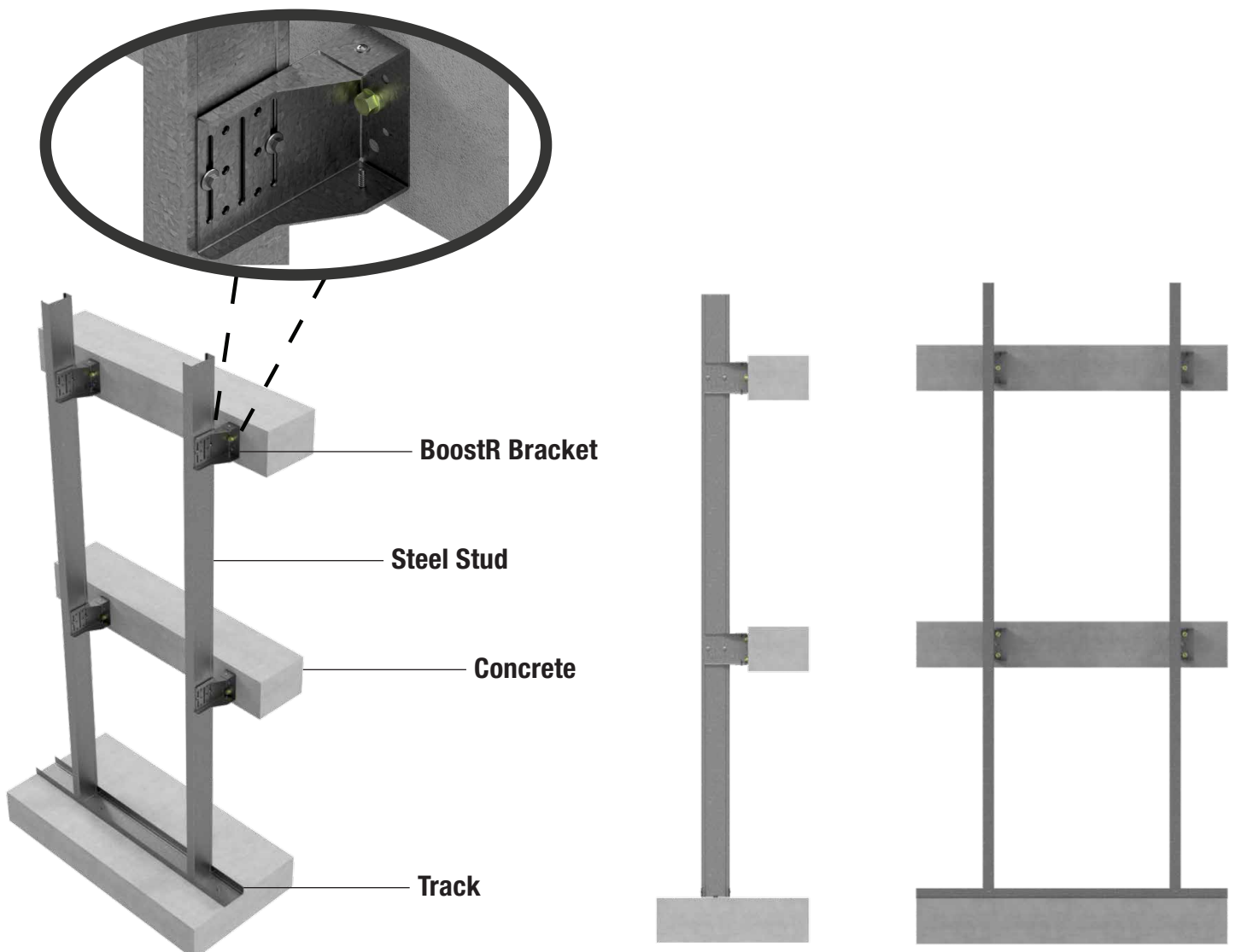

## BoostR Bracket Parts

Part No.	Length (mm)	Description	BMT	Weight (kg)	Stock Pack	Sub Pack	Weight of Pack (kg)
BB10	100	100mm (w) x 100mm (h) BoostR Bracket	1.5	0.26	25	25	6.5
BB15	150	100mm (w) x 150mm (h) BoostR Bracket	1.5	0.35	25	25	8.75
BB20	200	100mm (w) x 200mm (h) BoostR Bracket	1.5	0.39	25	25	9.75

## BoostR Bracket Components

BB10

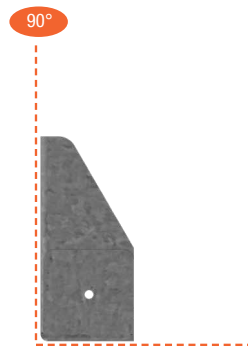
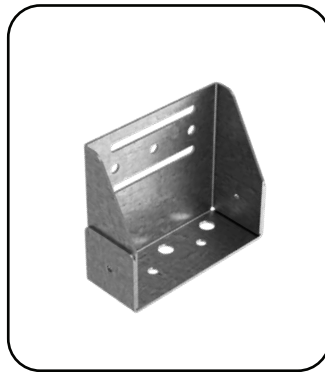

BB15

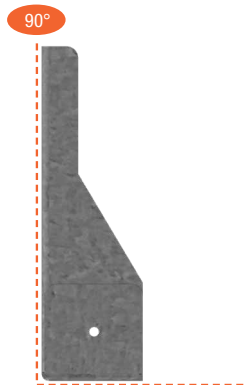
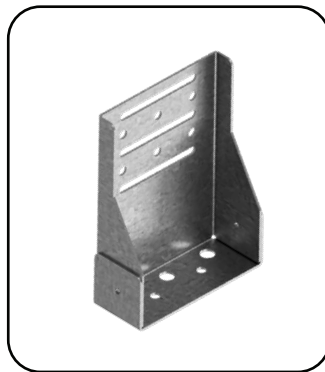

BB20

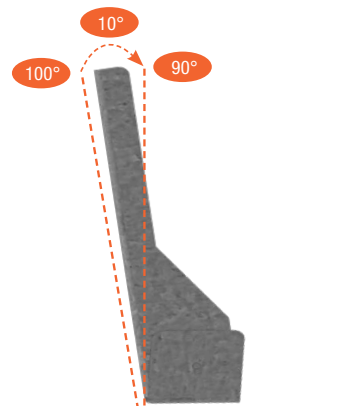
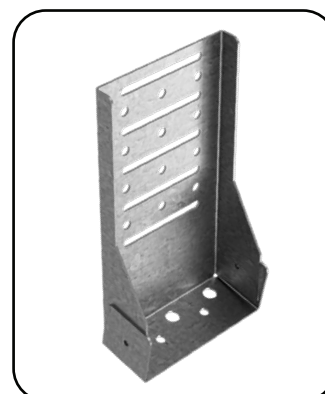

**Note:** Unlike BB10 and BB15, the BB20 arrives slightly open for ease of installation. See next page for details.

### A Quick Guide to Installing the BB20 BoostR Bracket

Prior to installation, you will notice that the BB20 bracket arrives slightly open (as below), and not at a 90-degree angle. The BB20 bracket is designed specifically this way to ensure ease of access for tools to secure fasteners.



#### Step 1

#### Fix the BB20 BoostR Bracket to structure using Fasteners.

Depending on the application, the BB20 BoostR Bracket can be fixed using one of three fixing conditions. (refer to Tables 1,2, and 3).



Fixing Condition 1



Fixing Condition 2



Fixing Condition 3

## Step 2

Once the BoostR Bracket is fixed to the structure, bend the bracket inward to 90 degrees so that the screw holes located on either side of the bracket align. Screw both sides in place.



## Step 3

The BB20 bracket is now ready to fix to steel stud.



## Step 4

Fix the steel stud to the slotted side of the bracket.

**#12g hex head screws** will be required in most cases to achieve the maximum shear capacities, however number of and actual gauge will be able to be manually adjusted by engineers as necessary.



**Table 1 — Fixing Condition 1 = One anchor fixed through hole #1 as shown**

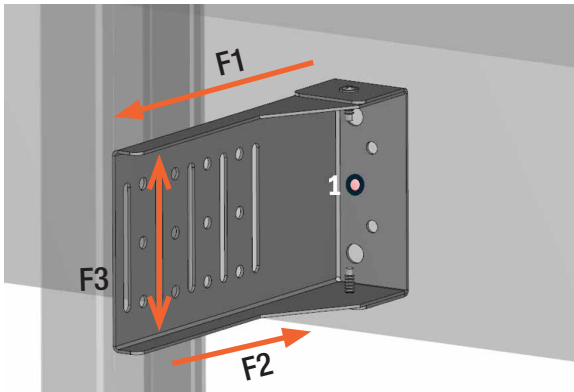

BoostR Bracket Part No.	BoostR Bracket Design Capacity (kN)		
	F1 <sub>Tension</sub>	F2 <sub>Compression</sub>	F3 <sub>Shear*</sub>
BB10	4.36	9.63	4.02
BB15	4.37	8.12	2.01
BB20	3.84	4.63	1.33

Note: \* = Shear capacity is only achieved when fixing through holes in BoostR bracket and not through slots

All design capacities are bracket capacities only and do not consider anchor, fastener or member capacities

**Table 2 — Fixing Condition 2 = Two anchors fixed through hole #'s 2 and 3 as shown**

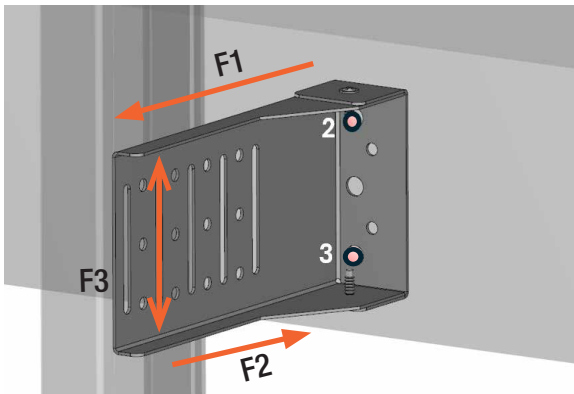

BoostR Bracket Part No.	BoostR Bracket Design Capacity (kN)		
	F1 <sub>Tension</sub>	F2 <sub>Compression</sub>	F3 <sub>Shear*</sub>
BB10	6.36	10.53	6.31
BB15	7	8.24	3.41
BB20	6.69	5.39	2.36

Note: \* = Shear capacity is only achieved when fixing through holes in BoostR bracket and not through slots

All design capacities are bracket capacities only and do not consider anchor, fastener or member capacities

**Table 3 — Fixing Condition 3 = Two fasteners fixed through hole #'s 4 and 5 as shown**

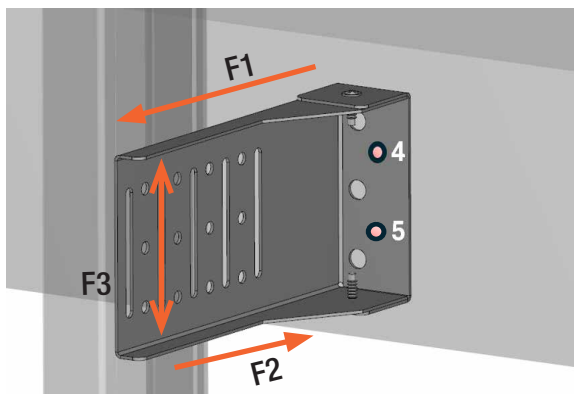

BoostR Bracket Part No.	BoostR Bracket Design Capacity (kN)		
	F1 <sub>Tension</sub>	F2 <sub>Compression</sub>	F3 <sub>Shear*</sub>
BB10	5.9	9.86	3.59
BB15	5.97	7.93	2.04
BB20	5.33	6.94	1.4

Note: \* = Shear capacity is only achieved when fixing through holes in BoostR bracket and not through slots

All design capacities are bracket capacities only and do not consider anchor, fastener or member capacities

# RONDO DESIGN SERVICES



For an efficient and compliant design for your next project, engage our Rondo Design Engineers to provide the very best product and customised design solutions.

To submit a technical enquiry form, **click [HERE](#)**.

**RONDO**<sup>®</sup>

[www.rondo.co.nz](http://www.rondo.co.nz)